

Conax Technologies Model MHM (Multi-Hole Metal) Glands can be customized to accommodate special hole patterns, irregular shapes and high density requirements. Like the MHC glands, MHM glands can be used to seal gradient thermocouple, RTD or thermistor probes, tube bundles or a variety of devices within a single fitting. The soft sealant technology seals against gases or liquids and resists element movement under pressure. Immersion lengths can be easily adjusted in the field. Individual elements can be set at different lengths to facilitate monitoring of multiple points. This style gland also allows easy replacement of elements.

MHM gland bodies with NPT threads or SAE threads are constructed from 303SST standard. Weld-neck style gland bodies are constructed from 316LSST standard. Caps, seats and followers for all styles are constructed from 303SST standard. Many optional materials are also available, including 316LSST, Inconel and more. For information on alternative materials, see page 9. Cap Style A offers a mounting thread only. Cap Style B provides threading on both ends for attachment to conduit or terminal heads. Alternative sealant materials and custom bore sizes are available. Please consult a Conax Technologies sales engineer for custom needs.

- Temperature Range: -400° F to +1600° F (-240° C to +870° C)
- Pressure Range: Vacuum to 10,000 PSIG (690 bar) – see Pressure Ratings in the Specifications Chart.
- Seals 1-27 Elements (standard)

### Accessories

The replaceable sealant permits repeated use of the same fitting. Elements can be easily assembled or replaced in the field. To replace the sealant or elements, simply loosen the cap, replace the necessary items, relubricate and retorque the cap.

Glands are supplied factory lubricated. When reused, the glands should be relubricated to maintain the published torque and pressure ratings. If glands are cleaned prior to assembly, they should be relubricated. On weld mount models, the heat from the welding process will destroy the lubricant. These models must also be relubricated prior to use. See page 103 for information on our lubrication kit.

To order a Replacement Packing Set, including sealant, seat and follower, order RPS – (Gland) – (Diameter) – (Number of Holes) – (Sealant)

#### Example: RPS-MHM5-040-16-T

To order a Replacement Sealant alone, order RS – (Gland) – (Diameter) – (Number of Holes) – (Sealant)

#### Example: RS-MHM5-040-16-T

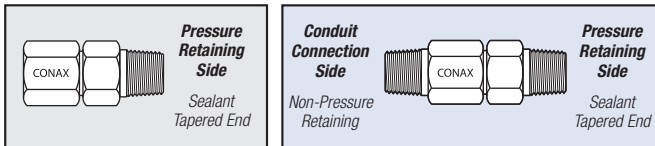

Type A has mounting thread only. Type B has cap end threaded. B Cap NPT matches the standard mounting NPT.

### Catalog Numbering System

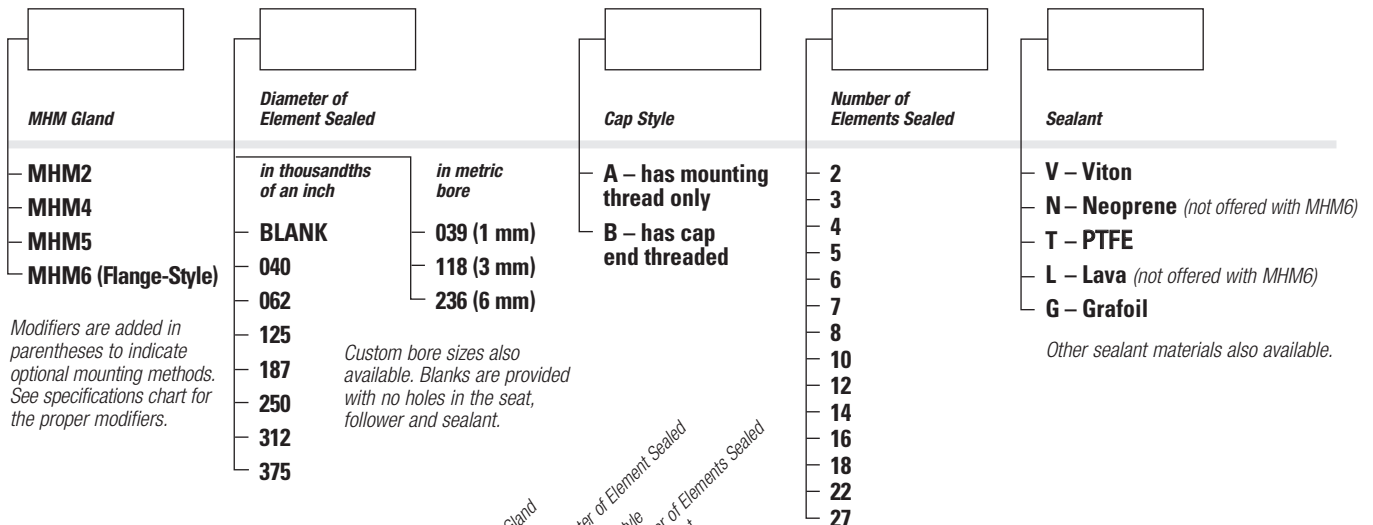

Example: **MHM5-040-B16-T**

See MHM selection guide to determine the standard number of elements offered with each model. For custom configurations, consult factory.

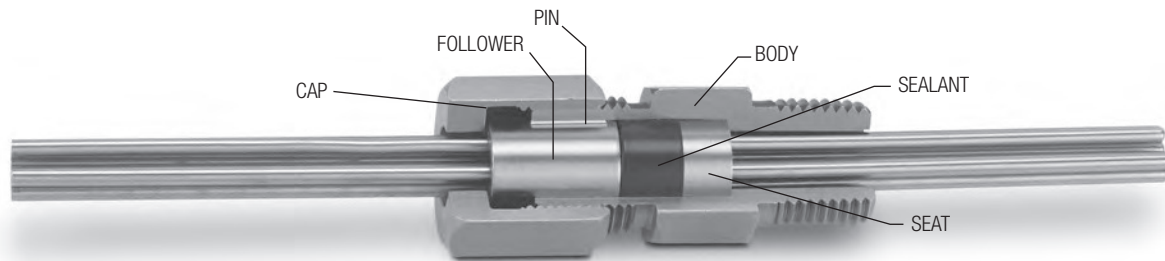

### MHM Selection Guide

Model	Diameter	Standard Number of Elements Offered															Max Hole Density
		2	3	4	5	6	7	8	10	12	14	16	18	22	27		
MHM2	039				X												8
	040				X												8
	062				X												5
MHM4	118		X	X													5
	125		X	X													4
MHM5	039								X	X			X				60
	040								X	X			X				60
	062								X	X			X				37
	118					X		X									15
	125					X		X									14
	187	X	X	X	X	X											6
	236	X	X	X													4
	250	X	X	X													4
MHM6	118								X					X	X	X	29
	125								X					X	X	X	27
	187							X	X	X	X						14
	236				X	X	X										8
	250				X	X	X										7
	312	X	X	X													5
	375	X	X	X													4

\*Consult factory for pressure ratings.

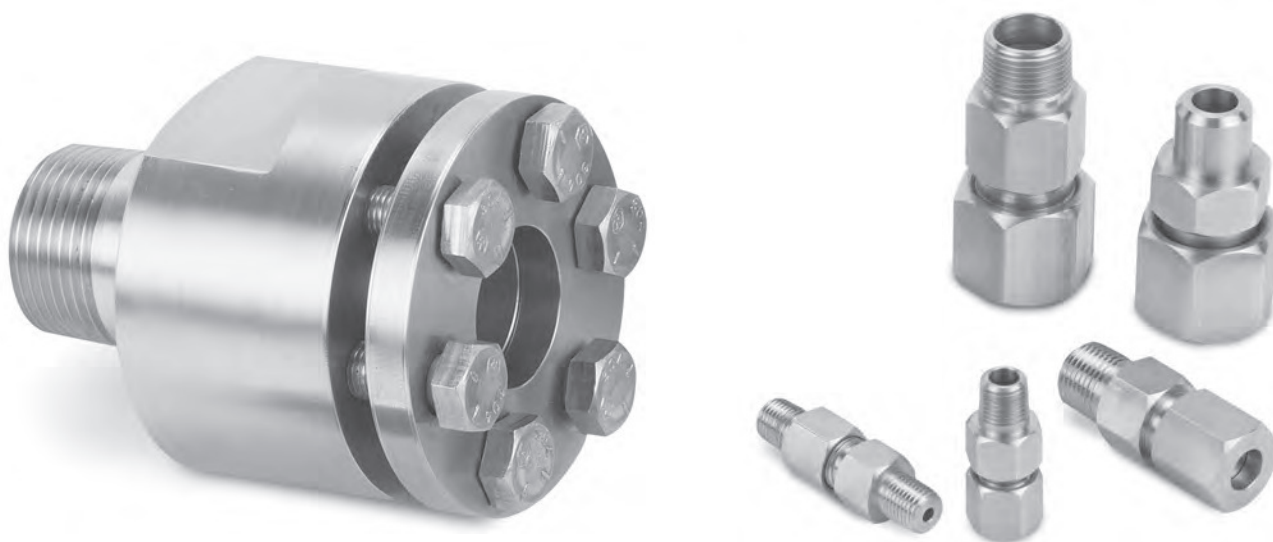

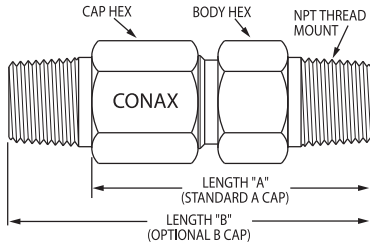

**Standard NPT**

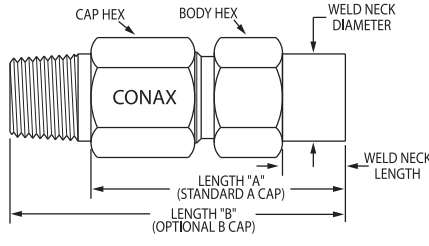

**Weld Neck Mount**

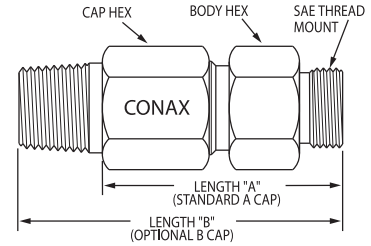

**SAE Thread Mount**

Catalog Number	Tube/Probe Diameter		Number of Probes	Length 'A'		Length 'B'		Hex Size				Pressure Rating									
	IN	MM		IN	MM	IN	MM	Body IN	Cap IN	Body MM	Cap MM	Neoprene PSIG	Neoprene BAR	Viton PSIG	Viton BAR	PTFE PSIG	PTFE BAR	Lava PSIG	Lava BAR	Grafoil PSIG	Grafoil BAR
<b>MODEL MHM2</b>																					
<b>Standard 1/4 NPT</b>																					
MHM2-BLANK	NA	NA	0	2.00	50.8	2.63	66.7	0.750	0.750	19.1	19.1	NA	NA	NA	NA	NA	NA	NA	NA	NA	NA
MHM2-039-5	0.039	0.99	5	2.00	50.8	2.63	66.7	0.750	0.750	19.1	19.1	NA	NA	10,000	689	3,200	220	10,000	689	8,000	551
MHM2-040-5	0.040	1.02	5	2.00	50.8	2.63	66.7	0.750	0.750	19.1	19.1	NA	NA	10,000	689	3,200	220	10,000	689	8,000	551
MHM2-062-5	0.062	1.57	5	2.00	50.8	2.63	66.7	0.750	0.750	19.1	19.1	4,000	276	10,000	689	2,400	165	10,000	689	6,400	441
<b>Weld Neck Mount (Weld Neck Mount Length 0.59", Diameter 0.540")</b>																					
MHM2(SWM2/S316L)-BLANK	NA	NA	0	2.00	50.8	2.63	66.7	0.750	0.750	19.1	19.1	NA	NA	NA	NA	NA	NA	NA	NA	NA	NA
MHM2(SWM2/S316L)-039-5	0.039	0.99	5	2.00	50.8	2.63	66.7	0.750	0.750	19.1	19.1	NA	NA	10,000	689	3,200	220	10,000	689	8,000	551
MHM2(SWM2/S316L)-040-5	0.040	1.02	5	2.00	50.8	2.63	66.7	0.750	0.750	19.1	19.1	NA	NA	10,000	689	3,200	220	10,000	689	8,000	551
MHM2(SWM2/S316L)-062-5	0.062	1.57	5	2.00	50.8	2.63	66.7	0.750	0.750	19.1	19.1	4,000	276	10,000	689	2,400	165	10,000	689	6,400	441
<b>SAE 3/4 -16 Thread Mount (formerly MS)</b>																					
MHM2(MSE8)-BLANK	NA	NA	0	2.00	50.8	2.63	66.7	1.000	0.750	25.4	19.1	NA	NA	NA	NA	NA	NA	NA	NA	NA	NA
MHM2(MSE8)-039-5	0.039	0.99	5	2.00	50.8	2.63	66.7	1.000	0.750	25.4	19.1	NA	NA	9,138	630	3,200	220	9,138	630	8,000	551
MHM2(MSE8)-040-5	0.040	1.02	5	2.00	50.8	2.63	66.7	1.000	0.750	25.4	19.1	NA	NA	9,138	630	3,200	220	9,138	630	8,000	551
MHM2(MSE8)-062-5	0.062	1.57	5	2.00	50.8	2.63	66.7	1.000	0.750	25.4	19.1	4,000	276	9,138	630	2,400	165	9,138	630	6,400	441
<b>MODEL MHM4</b>																					
<b>Standard 1/2 NPT</b>																					
MHM4-BLANK	NA	NA	0	2.56	65.1	3.38	85.7	1.000	1.000	25.4	25.4	NA	NA	NA	NA	NA	NA	NA	NA	NA	NA
MHM4-118-3	0.118	3.00	3	2.56	65.1	3.38	85.7	1.000	1.000	25.4	25.4	8,000	551	5,000	345	8,000	551	10,000	689	10,000	689
MHM4-118-4	0.118	3.00	4	2.56	65.1	3.38	85.7	1.000	1.000	25.4	25.4	8,000	551	5,000	345	8,000	551	10,000	689	10,000	689
MHM4-125-3	0.125	3.18	3	2.56	65.1	3.38	85.7	1.000	1.000	25.4	25.4	8,000	551	5,000	345	8,000	551	10,000	689	10,000	689
MHM4-125-4	0.125	3.18	4	2.56	65.1	3.38	85.7	1.000	1.000	25.4	25.4	8,000	551	5,000	345	8,000	551	10,000	689	10,000	689
<b>Weld Neck Mount (Weld Neck Mount Length 0.78", Diameter 0.840")</b>																					
MHM4(SWM4/S316L)-BLANK	NA	NA	0	2.56	65.1	3.38	85.7	1.000	1.000	25.4	25.4	NA	NA	NA	NA	NA	NA	NA	NA	NA	NA
MHM4(SWM4/S316L)-118-3	0.118	3.00	3	2.56	65.1	3.38	85.7	1.000	1.000	25.4	25.4	8,000	551	5,000	345	8,000	551	10,000	689	10,000	689
MHM4(SWM4/S316L)-118-4	0.118	3.00	4	2.56	65.1	3.38	85.7	1.000	1.000	25.4	25.4	8,000	551	5,000	345	8,000	551	10,000	689	10,000	689
MHM4(SWM4/S316L)-125-3	0.125	3.18	3	2.56	65.1	3.38	85.7	1.000	1.000	25.4	25.4	8,000	551	5,000	345	8,000	551	10,000	689	10,000	689
MHM4(SWM4/S316L)-125-4	0.125	3.18	4	2.56	65.1	3.38	85.7	1.000	1.000	25.4	25.4	8,000	551	5,000	345	8,000	551	10,000	689	10,000	689
<b>SAE 7/8 -14 Thread Mount (formerly MS)</b>																					
MHM4(MSE10)-Blank	NA	NA	0	2.56	65.1	3.38	85.7	1.375	1.000	34.9	25.4	NA	NA	NA	NA	NA	NA	NA	NA	NA	NA
MHM4(MSE10)-118-3	0.118	3.00	3	2.56	65.1	3.38	85.7	1.375	1.000	34.9	25.4	8,000	551	5,000	345	8,000	551	9,138	630	9,138	630
MHM4(MSE10)-118-4	0.118	3.00	4	2.56	65.1	3.38	85.7	1.375	1.000	34.9	25.4	8,000	551	5,000	345	8,000	551	9,138	630	9,138	630
MHM4(MSE10)-125-3	0.125	3.18	3	2.56	65.1	3.38	85.7	1.375	1.000	34.9	25.4	8,000	551	5,000	345	8,000	551	9,138	630	9,138	630
MHM4(MSE10)-125-4	0.125	3.18	4	2.56	65.1	3.38	85.7	1.375	1.000	34.9	25.4	8,000	551	5,000	345	8,000	551	9,138	630	9,138	630

Note: the pressure and torque ratings provided in this catalog apply only when bores are drilled by Conax Technologies.

\* Hex size for the body and cap are the same unless a cap size is provided in parentheses. Blanks are provided with no holes in the body, follower and sealant.

\*\* Weld neck models require lubrication prior to use.

N/O = Not Offered, NA = Not Applicable

## MULTIPLE ELEMENT SEALING (MULTI-HOLE METAL GLANDS) ■ MHM SERIES

Catalog Number	Tube/Probe Diameter		Number of Probes	Length 'A'		Length 'B'		Hex Size				Pressure Rating									
	IN	MM		IN	MM	IN	MM	Body IN	Cap IN	Body MM	Cap MM	Neoprene		Viton		PTFE		Lava		Grafoil	
MODEL MHM5												PSIG	BAR	PSIG	BAR	PSIG	BAR	PSIG	BAR	PSIG	BAR
<b>Standard 3/4 NPT</b>																					
MHM5-BLANK	NA	NA	0	3.31	84.1	4.06	103.1	1.250	1.500	31.8	38.1	NA	NA	NA	NA	NA	NA	NA	NA	NA	NA
MHM5-039-10	0.039	0.99	10	3.31	84.1	4.06	103.1	1.250	1.500	31.8	38.1	5,200	358	6,800	469	4,500	310	2,000	138	4,000	276
MHM5-039-12	0.039	0.99	12	3.31	84.1	4.06	103.1	1.250	1.500	31.8	38.1	5,200	358	6,800	469	4,500	310	2,500	172	4,500	310
MHM5-039-16	0.039	0.99	16	3.31	84.1	4.06	103.1	1.250	1.500	31.8	38.1	5,200	358	6,800	469	4,500	310	3,000	207	4,500	310
MHM5-040-10	0.040	1.02	10	3.31	84.1	4.06	103.1	1.250	1.500	31.8	38.1	5,200	358	6,800	469	4,500	310	2,000	138	4,000	276
MHM5-040-12	0.040	1.02	12	3.31	84.1	4.06	103.1	1.250	1.500	31.8	38.1	5,200	358	6,800	469	4,500	310	2,500	172	4,500	310
MHM5-040-16	0.040	1.02	16	3.31	84.1	4.06	103.1	1.250	1.500	31.8	38.1	5,200	358	6,800	469	4,500	310	3,000	207	4,500	310
MHM5-062-10	0.062	1.57	10	3.31	84.1	4.06	103.1	1.250	1.500	31.8	38.1	3,200	220	7,200	496	6,000	413	7,000	482	6,500	448
MHM5-062-12	0.062	1.57	12	3.31	84.1	4.06	103.1	1.250	1.500	31.8	38.1	3,200	220	7,200	496	6,000	413	7,000	482	6,500	448
MHM5-062-16	0.062	1.57	16	3.31	84.1	4.06	103.1	1.250	1.500	31.8	38.1	3,200	220	7,200	496	6,000	413	7,000	482	6,500	448
MHM5-118-6	0.118	3.00	6	3.31	84.1	4.06	103.1	1.250	1.500	31.8	38.1	4,000	276	4,500	310	4,500	310	6,000	413	4,500	310
MHM5-118-8	0.118	3.00	8	3.31	84.1	4.06	103.1	1.250	1.500	31.8	38.1	4,000	276	4,500	310	4,500	310	6,000	413	4,500	310
MHM5-125-6	0.125	3.18	6	3.31	84.1	4.06	103.1	1.250	1.500	31.8	38.1	4,000	276	4,500	310	4,500	310	6,000	413	4,500	310
MHM5-125-8	0.125	3.18	8	3.31	84.1	4.06	103.1	1.250	1.500	31.8	38.1	4,000	276	4,500	310	4,500	310	6,000	413	4,500	310
MHM5-187-2	0.187	4.75	2	3.31	84.1	4.06	103.1	1.250	1.500	31.8	38.1	1,200	83	6,800	469	1,600	110	8,400	579	8,000	551
MHM5-187-3	0.187	4.75	3	3.31	84.1	4.06	103.1	1.250	1.500	31.8	38.1	1,200	83	6,800	469	1,600	110	8,400	579	8,000	551
MHM5-187-4	0.187	4.75	4	3.31	84.1	4.06	103.1	1.250	1.500	31.8	38.1	1,200	83	6,800	469	1,600	110	8,400	579	8,000	551
MHM5-187-5	0.187	4.75	5	3.31	84.1	4.06	103.1	1.250	1.500	31.8	38.1	1,200	83	6,800	469	1,600	110	8,400	579	8,000	551
MHM5-187-6	0.187	4.75	6	3.31	84.1	4.06	103.1	1.250	1.500	31.8	38.1	1,200	83	6,800	469	1,600	110	8,400	579	8,000	551
MHM5-236-2	0.236	5.99	2	3.31	84.1	4.06	103.1	1.250	1.500	31.8	38.1	4,300	296	5,000	345	1,600	110	6,700	462	4,500	310
MHM5-236-3	0.236	5.99	3	3.31	84.1	4.06	103.1	1.250	1.500	31.8	38.1	4,300	296	5,000	345	1,600	110	6,700	462	4,500	310
MHM5-236-4	0.236	5.99	4	3.31	84.1	4.06	103.1	1.250	1.500	31.8	38.1	4,300	296	5,000	345	1,600	110	6,700	462	4,500	310
MHM5-250-2	0.250	6.35	2	3.31	84.1	4.06	103.1	1.250	1.500	31.8	38.1	4,300	296	5,000	345	1,600	110	6,700	462	4,500	310
MHM5-250-3	0.250	6.35	3	3.31	84.1	4.06	103.1	1.250	1.500	31.8	38.1	4,300	296	5,000	345	1,600	110	6,700	462	4,500	310
MHM5-250-4	0.250	6.35	4	3.31	84.1	4.06	103.1	1.250	1.500	31.8	38.1	4,300	296	5,000	345	1,600	110	6,700	462	4,500	310
<b>Weld Neck Mount (Weld Neck Mount Length 0.79", Diameter 1.050")<sub>min</sub></b>																					
MHM5(SWM5/S316L)-BLANK	NA	NA		3.31	84.1	4.06	103.1	1.250	1.500	31.8	38.1	NA	NA	NA	NA	NA	NA	NA	NA	NA	NA
MHM5(SWM5/S316L)-039-10	0.039	0.99	0	3.31	84.1	4.06	103.1	1.250	1.500	31.8	38.1	5,200	358	6,800	469	4,500	310	2,000	138	4,000	276
MHM5(SWM5/S316L)-039-12	0.039	0.99	2	3.31	84.1	4.06	103.1	1.250	1.500	31.8	38.1	5,200	358	6,800	469	4,500	310	2,500	172	4,500	310
MHM5(SWM5/S316L)-039-16	0.039	0.99	6	3.31	84.1	4.06	103.1	1.250	1.500	31.8	38.1	5,200	358	6,800	469	4,500	310	3,000	207	4,500	310
MHM5(SWM5/S316L)-040-10	0.040	1.02	10	3.31	84.1	4.06	103.1	1.250	1.500	31.8	38.1	5,200	358	6,800	469	4,500	310	2,000	138	4,000	276
MHM5(SWM5/S316L)-040-12	0.040	1.02	12	3.31	84.1	4.06	103.1	1.250	1.500	31.8	38.1	5,200	358	6,800	469	4,500	310	2,500	172	4,500	310
MHM5(SWM5/S316L)-040-16	0.040	1.02	16	3.31	84.1	4.06	103.1	1.250	1.500	31.8	38.1	5,200	358	6,800	469	4,500	310	3,000	207	4,500	310
MHM5(SWM5/S316L)-062-10	0.062	1.57	10	3.31	84.1	4.06	103.1	1.250	1.500	31.8	38.1	3,200	220	7,200	496	6,000	413	7,000	482	6,500	448
MHM5(SWM5/S316L)-062-12	0.062	1.57	12	3.31	84.1	4.06	103.1	1.250	1.500	31.8	38.1	3,200	220	7,200	496	6,000	413	7,000	482	6,500	448
MHM5(SWM5/S316L)-062-16	0.062	1.57	16	3.31	84.1	4.06	103.1	1.250	1.500	31.8	38.1	3,200	220	7,200	496	6,000	413	7,000	482	6,500	448
MHM5(SWM5/S316L)-118-6	0.118	3.00	6	3.31	84.1	4.06	103.1	1.250	1.500	31.8	38.1	4,000	276	4,500	310	4,500	310	6,000	413	4,500	310
MHM5(SWM5/S316L)-118-8	0.118	3.00	8	3.31	84.1	4.06	103.1	1.250	1.500	31.8	38.1	4,000	276	4,500	310	4,500	310	6,000	413	4,500	310
MHM5(SWM5/S316L)-125-6	0.125	3.18	6	3.31	84.1	4.06	103.1	1.250	1.500	31.8	38.1	4,000	276	4,500	310	4,500	310	6,000	413	4,500	310
MHM5(SWM5/S316L)-125-8	0.125	3.18	8	3.31	84.1	4.06	103.1	1.250	1.500	31.8	38.1	4,000	276	4,500	310	4,500	310	6,000	413	4,500	310
MHM5(SWM5/S316L)-187-2	0.187	4.75	2	3.31	84.1	4.06	103.1	1.250	1.500	31.8	38.1	1,200	83	6,800	469	1,600	110	8,400	579	8,000	551

C/F = Consult factory. NA = Not Applicable

All pressure and torque ratings were determined at 68° F (20° C) using stainless steel rod as the element. Pressure ratings may degrade at higher temperatures. Pressure rating guide values are provided for glands with elements restrained by the compressed sealant. Higher pressure may be attained with additional element restraints. Tolerance of tube or probe diameter is ±0.005 (±0.003 for diameters ≤0.040). Deviation from the nominal may affect pressure ratings. Consult factory for details.

**CAUTION:** When sealing on soft, fragile or crushable elements, catalog torques may not apply. When catalog torques are applied, compressed sealants generate considerable forces on the element to be sealed. These forces could result in damaging soft or fragile elements such as coax cables or thin-wall materials. Consult factory for these types of applications.

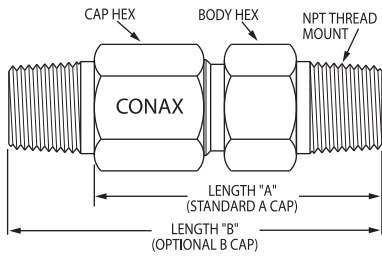

**Standard NPT**

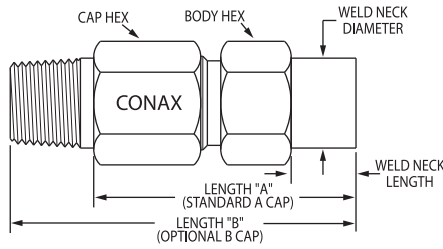

**Weld Neck Mount**

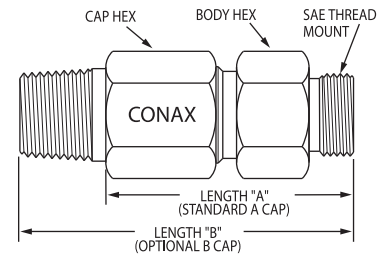

**SAE Thread Mount**

Catalog Number	Tube/Probe Diameter		Number of Probes	Length 'A'		Length 'B'		Hex Size				Pressure Rating									
	IN	MM		IN	MM	IN	MM	Body IN	Cap IN	Body MM	Cap MM	Neoprene		Viton		PTFE		Lava		Grafoil	
MODEL MHM5												PSIG	BAR	PSIG	BAR	PSIG	BAR	PSIG	BAR	PSIG	BAR
<b>Weld Neck Mount (Weld Neck Mount Length 0.79", Diameter 1.050")</b>																					
MHM5(SWM5/S316L)-187-3	0.187	4.75	3	3.31	84.1	4.06	103.1	1.250	1.500	31.8	38.1	1,200	83	6,800	469	1,600	110	8,400	579	8,000	551
MHM5(SWM5/S316L)-187-4	0.187	4.75	4	3.31	84.1	4.06	103.1	1.250	1.500	31.8	38.1	1,200	83	6,800	469	1,600	110	8,400	579	8,000	551
MHM5(SWM5/S316L)-187-5	0.187	4.75	5	3.31	84.1	4.06	103.1	1.250	1.500	31.8	38.1	1,200	83	6,800	469	1,600	110	8,400	579	8,000	551
MHM5(SWM5/S316L)-187-6	0.187	4.75	6	3.31	84.1	4.06	103.1	1.250	1.500	31.8	38.1	1,200	83	6,800	469	1,600	110	8,400	579	8,000	551
MHM5(SWM5/S316L)-236-2	0.236	5.99	2	3.31	84.1	4.06	103.1	1.250	1.500	31.8	38.1	4,300	296	5,000	345	1,600	110	6,700	462	4,500	310
MHM5(SWM5/S316L)-236-3	0.236	5.99	3	3.31	84.1	4.06	103.1	1.250	1.500	31.8	38.1	4,300	296	5,000	345	1,600	110	6,700	462	4,500	310
MHM5(SWM5/S316L)-236-4	0.236	5.99	4	3.31	84.1	4.06	103.1	1.250	1.500	31.8	38.1	4,300	296	5,000	345	1,600	110	6,700	462	4,500	310
MHM5(SWM5/S316L)-250-2	0.250	6.35	2	3.31	84.1	4.06	103.1	1.250	1.500	31.8	38.1	4,300	296	5,000	345	1,600	110	6,700	462	4,500	310
MHM5(SWM5/S316L)-250-3	0.250	6.35	3	3.31	84.1	4.06	103.1	1.250	1.500	31.8	38.1	4,300	296	5,000	345	1,600	110	6,700	462	4,500	310
MHM5(SWM5/S316L)-250-4	0.250	6.35	4	3.31	84.1	4.06	103.1	1.250	1.500	31.8	38.1	4,300	296	5,000	345	1,600	110	6,700	462	4,500	310
<b>SAE 1-5/16 -12 Thread Mount (formerly MS)</b>																					
MHM5(MSE16)-BLANK	NA	NA	0	3.31	84.1	4.06	103.1	1.625	1.500	41.3	38.1	NA	NA	NA	NA	NA	NA	NA	NA	NA	NA
MHM5(MSE16)-039-10	0.039	0.99	10	3.31	84.1	4.06	103.1	1.625	1.500	41.3	38.1	5,200	358	5,802	400	4,500	310	2,000	138	4,000	276
MHM5(MSE16)-039-12	0.039	0.99	12	3.31	84.1	4.06	103.1	1.625	1.500	41.3	38.1	5,200	358	5,802	400	4,500	310	2,500	172	4,500	310
MHM5(MSE16)-039-16	0.039	0.99	16	3.31	84.1	4.06	103.1	1.625	1.500	41.3	38.1	5,200	358	5,802	400	4,500	310	3,000	207	4,500	310
MHM5(MSE16)-040-10	0.040	1.02	10	3.31	84.1	4.06	103.1	1.625	1.500	41.3	38.1	5,200	358	5,802	400	4,500	310	2,000	138	4,000	276
MHM5(MSE16)-040-12	0.040	1.02	12	3.31	84.1	4.06	103.1	1.625	1.500	41.3	38.1	5,200	358	5,802	400	4,500	310	2,500	172	4,500	310
MHM5(MSE16)-040-16	0.040	1.02	16	3.31	84.1	4.06	103.1	1.625	1.500	41.3	38.1	5,200	358	5,802	400	4,500	310	3,000	207	4,500	310
MHM5(MSE16)-062-10	0.062	1.57	10	3.31	84.1	4.06	103.1	1.625	1.500	41.3	38.1	3,200	220	5,802	400	5,802	400	5,802	400	5,802	400
MHM5(MSE16)-062-12	0.062	1.57	12	3.31	84.1	4.06	103.1	1.625	1.500	41.3	38.1	3,200	220	5,802	400	5,802	400	5,802	400	5,802	400
MHM5(MSE16)-062-16	0.062	1.57	16	3.31	84.1	4.06	103.1	1.625	1.500	41.3	38.1	3,200	220	5,802	400	5,802	400	5,802	400	5,802	400
MHM5(MSE16)-118-6	0.118	3.00	6	3.31	84.1	4.06	103.1	1.625	1.500	41.3	38.1	4,000	276	4,500	310	4,500	310	5,802	400	4,500	310
MHM5(MSE16)-118-8	0.118	3.00	8	3.31	84.1	4.06	103.1	1.625	1.500	41.3	38.1	4,000	276	4,500	310	4,500	310	5,802	400	4,500	310
MHM5(MSE16)-125-6	0.125	3.18	6	3.31	84.1	4.06	103.1	1.625	1.500	41.3	38.1	4,000	276	4,500	310	4,500	310	5,802	400	4,500	310
MHM5(MSE16)-125-8	0.125	3.18	8	3.31	84.1	4.06	103.1	1.625	1.500	41.3	38.1	4,000	276	4,500	310	4,500	310	5,802	400	4,500	310
MHM5(MSE16)-187-2	0.187	4.75	2	3.31	84.1	4.06	103.1	1.625	1.500	41.3	38.1	1,200	83	5,802	400	1,600	110	5,802	400	5,802	400
MHM5(MSE16)-187-3	0.187	4.75	3	3.31	84.1	4.06	103.1	1.625	1.500	41.3	38.1	1,200	83	5,802	400	1,600	110	5,802	400	5,802	400
MHM5(MSE16)-187-4	0.187	4.75	4	3.31	84.1	4.06	103.1	1.625	1.500	41.3	38.1	1,200	83	5,802	400	1,600	110	5,802	400	5,802	400
MHM5(MSE16)-187-5	0.187	4.75	5	3.31	84.1	4.06	103.1	1.625	1.500	41.3	38.1	1,200	83	5,802	400	1,600	110	5,802	400	5,802	400
MHM5(MSE16)-187-6	0.187	4.75	6	3.31	84.1	4.06	103.1	1.625	1.500	41.3	38.1	1,200	83	5,802	400	1,600	110	5,802	400	5,802	400
MHM5(MSE16)-236-2	0.236	5.99	2	3.31	84.1	4.06	103.1	1.625	1.500	41.3	38.1	4,300	296	5,000	345	1,600	110	5,802	400	4,500	310
MHM5(MSE16)-236-3	0.236	5.99	3	3.31	84.1	4.06	103.1	1.625	1.500	41.3	38.1	4,300	296	5,000	345	1,600	110	5,802	400	4,500	310
MHM5(MSE16)-236-4	0.236	5.99	4	3.31	84.1	4.06	103.1	1.625	1.500	41.3	38.1	4,300	296	5,000	345	1,600	110	5,802	400	4,500	310
MHM5(MSE16)-250-2	0.250	6.35	2	3.31	84.1	4.06	103.1	1.625	1.500	41.3	38.1	4,300	296	5,000	345	1,600	110	5,802	400	4,500	310
MHM5(MSE16)-250-3	0.250	6.35	3	3.31	84.1	4.06	103.1	1.625	1.500	41.3	38.1	4,300	296	5,000	345	1,600	110	5,802	400	4,500	310
MHM5(MSE16)-250-4	0.250	6.35	4	3.31	84.1	4.06	103.1	1.625	1.500	41.3	38.1	4,300	296	5,000	345	1,600	110	5,802	400	4,500	310

Note: the pressure and torque ratings provided in this catalog apply only when bores are drilled by Conax Technologies.

\* Hex size for the body and cap are the same unless a cap size is provided in parentheses. Blanks are provided with no holes in the body, follower and sealant.

\*\* Weld neck models require lubrication prior to use.

N/O = Not Offered, NA = Not Applicable.

**CAUTION:** When sealing on soft, fragile or crushable elements, catalog torques may not apply. When catalog torques are applied, compressed sealants generate considerable forces on the element to be sealed. These forces could result in damaging soft or fragile elements such as coax cables or thin-wall materials. Consult factory for these types of applications.

# MULTIPLE ELEMENT SEALING (MULTI-HOLE METAL GLANDS) ■ MHM SERIES

# 5001D

Catalog Number	Tube/Probe Diameter		Number of Probes	Length 'A'		Length 'B'		Flange/Body Diameter		Pressure Rating					
	IN	MM		IN	MM	IN	MM	IN	MM	Viton		PTFE		Grafoil	
	PSIG	BAR	PSIG	BAR	PSIG	BAR	PSIG	BAR	PSIG	BAR	PSIG	BAR	PSIG	BAR	
<b>MODEL MHM6</b>															
<b>Standard 1 NPT</b>															
MHM6-BLANK	NA	NA	0	3.80	96.5	5.00	127.0	2.75	69.9	NA	NA	NA	NA	NA	NA
MHM6-118-10	0.118	3.0	10	3.80	96.5	5.00	127.0	2.75	69.9	10,000	689	1,500	103	2,400	16
MHM6-118-18	0.118	3.0	18	3.80	96.5	5.00	127.0	2.75	69.9	10,000	689	1,500	103	2,400	165
MHM6-118-22	0.118	3.0	2	3.80	96.5	5.00	127.0	2.75	69.9	10,000	689	1,500	103	2,400	165
MHM6-118-27	0.118	3.0	27	3.80	96.5	5.00	127.0	2.75	69.9	10,000	689	1,500	103	2,400	165
MHM6-125-10	0.125	3.2	10	3.80	96.5	5.00	127.0	2.75	69.9	10,000	689	1,500	103	2,400	165
MHM6-125-18	0.125	3.2	18	3.80	96.5	5.00	127.0	2.75	69.9	10,000	689	1,500	103	2,400	165
MHM6-125-22	0.125	3.2	22	3.80	96.5	5.00	127.0	2.75	69.9	10,000	689	1,500	103	2,400	165
MHM6-125-27	0.125	3.2	27	3.80	96.5	5.00	127.0	2.75	69.9	10,000	689	1,500	103	2,400	165
MHM6-187-8	0.187	4.7	8	3.80	96.5	5.00	127.0	2.75	69.9	6,000	413	1,000	69	1,000	69
MHM6-187-10	0.187	4.7	10	3.80	96.5	5.00	127.0	2.75	69.9	6,000	413	1,000	69	1,000	69
MHM6-187-12	0.187	4.7	12	3.80	96.5	5.00	127.0	2.75	69.9	6,000	413	1,000	69	1,000	69
MHM6-187-14	0.187	4.7	14	3.80	96.5	5.00	127.0	2.75	69.9	6,000	413	1,000	69	1,000	69
MHM6-236-5	0.236	6.0	5	3.80	96.5	5.00	127.0	2.75	69.9	6,000	413	1,000	69	1,000	69
MHM6-236-6	0.236	6.0	6	3.80	96.5	5.00	127.0	2.75	69.9	6,000	413	1,000	69	1,000	69
MHM6-236-7	0.236	6.0	7	3.80	96.5	5.00	127.0	2.75	69.9	6,000	413	1,000	69	1,000	69
MHM6-250-5	0.250	6.4	5	3.80	96.5	5.00	127.0	2.75	69.9	6,000	413	1,000	69	1,000	69
MHM6-250-6	0.250	6.4	6	3.80	96.5	5.00	127.0	2.75	69.9	6,000	413	1,000	69	1,000	69
MHM6-250-7	0.250	6.4	7	3.80	96.5	5.00	127.0	2.75	69.9	6,000	413	1,000	69	1,000	69
MHM6-312-2	0.312	7.9	2	3.80	96.5	5.00	127.0	2.75	69.9	3,000	207	1,000	69	1,000	69
MHM6-312-3	0.312	7.9	3	3.80	96.5	5.00	127.0	2.75	69.9	3,000	207	1,000	69	1,000	69
MHM6-312-4	0.312	7.9	4	3.80	96.5	5.00	127.0	2.75	69.9	3,000	207	1,000	69	1,000	69
MHM6-375-2	0.375	9.5	2	3.80	96.5	5.00	127.0	2.75	69.9	3,000	207	1,000	69	1,000	69
MHM6-375-3	0.375	9.5	3	3.80	96.5	5.00	127.0	2.75	69.9	3,000	207	1,000	69	1,000	69
MHM6-375-4	0.375	9.5	4	3.80	96.5	5.00	127.0	2.75	69.9	3,000	207	1,000	69	1,000	69
<b>Weld Neck Mount (Weld Neck Mount Length 0.98", Diameter 1.315")**</b>															
MHM6-BLANK	NA	NA	0	3.80	96.5	5.00	127.0	2.75	69.9	NA	NA	NA	NA	NA	NA
MHM6(SWM6/S316L)-118-10	0.118	3.0	10	3.80	96.5	5.00	127.0	2.75	69.9	10,000	689	1,500	103	2,400	165
MHM6(SWM6/S316L)-118-18	0.118	3.0	18	3.80	96.5	5.00	127.0	2.75	69.9	10,000	689	1,500	103	2,400	165
MHM6(SWM6/S316L)-118-22	0.118	3.0	22	3.80	96.5	5.00	127.0	2.75	69.9	10,000	689	1,500	103	2,400	165
MHM6(SWM6/S316L)-118-27	0.118	3.0	27	3.80	96.5	5.00	127.0	2.75	69.9	10,000	689	1,500	103	2,400	165
MHM6(SWM6/S316L)-125-10	0.125	3.2	10	3.80	96.5	5.00	127.0	2.75	69.9	10,000	689	1,500	103	2,400	165
MHM6(SWM6/S316L)-125-18	0.125	3.2	18	3.80	96.5	5.00	127.0	2.75	69.9	10,000	689	1,500	103	2,400	165
MHM6(SWM6/S316L)-125-22	0.125	3.2	22	3.80	96.5	5.00	127.0	2.75	69.9	10,000	689	1,500	103	2,400	165
MHM6(SWM6/S316L)-125-27	0.125	3.2	27	3.80	96.5	5.00	127.0	2.75	69.9	10,000	689	1,500	103	2,400	165
MHM6(SWM6/S316L)-187-8	0.187	4.7	8	3.80	96.5	5.00	127.0	2.75	69.9	6,000	413	1,000	69	1,000	69
MHM6(SWM6/S316L)-187-10	0.187	4.7	10	3.80	96.5	5.00	127.0	2.75	69.9	6,000	413	1,000	69	1,000	69
MHM6(SWM6/S316L)-187-12	0.187	4.7	12	3.80	96.5	5.00	127.0	2.75	69.9	6,000	413	1,000	69	1,000	69
MHM6(SWM6/S316L)-187-14	0.187	4.7	14	3.80	96.5	5.00	127.0	2.75	69.9	6,000	413	1,000	69	1,000	69
MHM6(SWM6/S316L)-236-5	0.236	6.0	5	3.80	96.5	5.00	127.0	2.75	69.9	6,000	413	1,000	69	1,000	69
MHM6(SWM6/S316L)-236-6	0.236	6.0	6	3.80	96.5	5.00	127.0	2.75	69.9	6,000	413	1,000	69	1,000	69
MHM6(SWM6/S316L)-236-7	0.236	6.0	7	3.80	96.5	5.00	127.0	2.75	69.9	6,000	413	1,000	69	1,000	69
MHM6(SWM6/S316L)-250-5	0.250	6.4	5	3.80	96.5	5.00	127.0	2.75	69.9	6,000	413	1,000	69	1,000	69
MHM6(SWM6/S316L)-250-6	0.250	6.4	6	3.80	96.5	5.00	127.0	2.75	69.9	6,000	413	1,000	69	1,000	69
MHM6(SWM6/S316L)-250-7	0.250	6.4	7	3.80	96.5	5.00	127.0	2.75	69.9	6,000	413	1,000	69	1,000	69
MHM6(SWM6/S316L)-312-2	0.312	7.9	2	3.80	96.5	5.00	127.0	2.75	69.9	3,000	207	1,000	69	1,000	69
MHM6(SWM6/S316L)-312-3	0.312	7.9	3	3.80	96.5	5.00	127.0	2.75	69.9	3,000	207	1,000	69	1,000	69
MHM6(SWM6/S316L)-312-4	0.312	7.9	4	3.80	96.5	5.00	127.0	2.75	69.9	3,000	207	1,000	69	1,000	69
MHM6(SWM6/S316L)-375-2	0.375	9.5	2	3.80	96.5	5.00	127.0	2.75	69.9	3,000	207	1,000	69	1,000	69
MHM6(SWM6/S316L)-375-3	0.375	9.5	3	3.80	96.5	5.00	127.0	2.75	69.9	3,000	207	1,000	69	1,000	69
MHM6(SWM6/S316L)-375-4	0.375	9.5	4	3.80	96.5	5.00	127.0	2.75	69.9	3,000	207	1,000	69	1,000	69

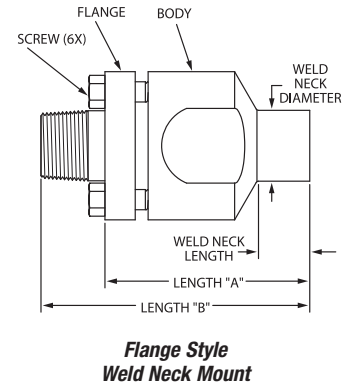
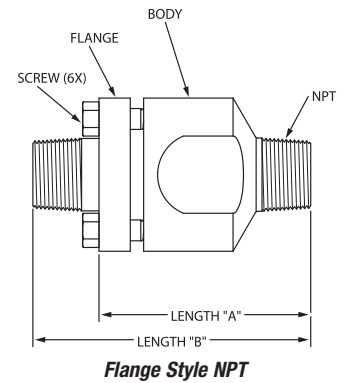

SPLIT SEALS

C/F = Consult factory. NA = Not Applicable.

All pressure and torque ratings were determined at 68° F (20° C) using stainless steel rod as the element. Pressure ratings may degrade at higher temperatures. Pressure rating guide values are provided for glands with elements restrained by the compressed sealant. Higher pressure may be attained with additional element restraints. Tolerance of tube or probe diameter is ±0.005 (±0.003 for diameters ≤0.040). Deviation from the nominal may affect pressure ratings. Consult factory for details.